

A-2-D-400-CERT-N

Tapa y marco modelo "SEVILLANA", certificada por AENOR de medidas exteriores 1262 x 734 mm y paso libre de 1142 x 614 mm.

Revision: 01 - 13/12/2018

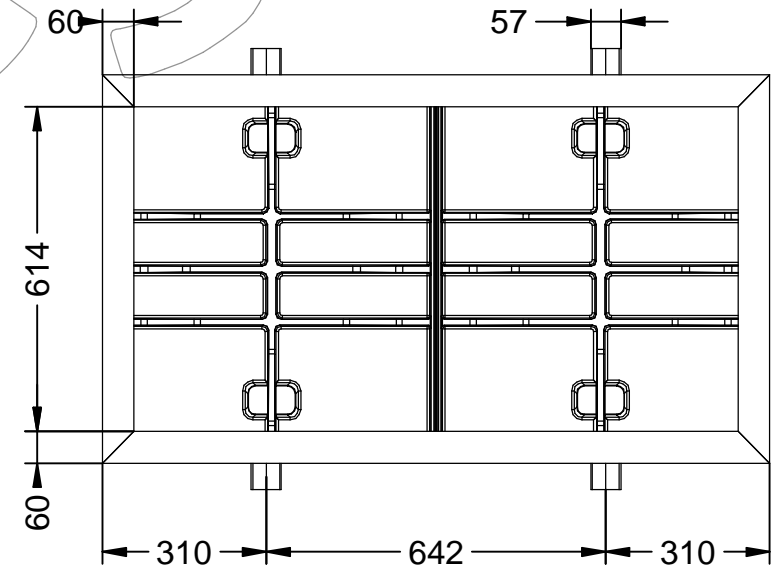
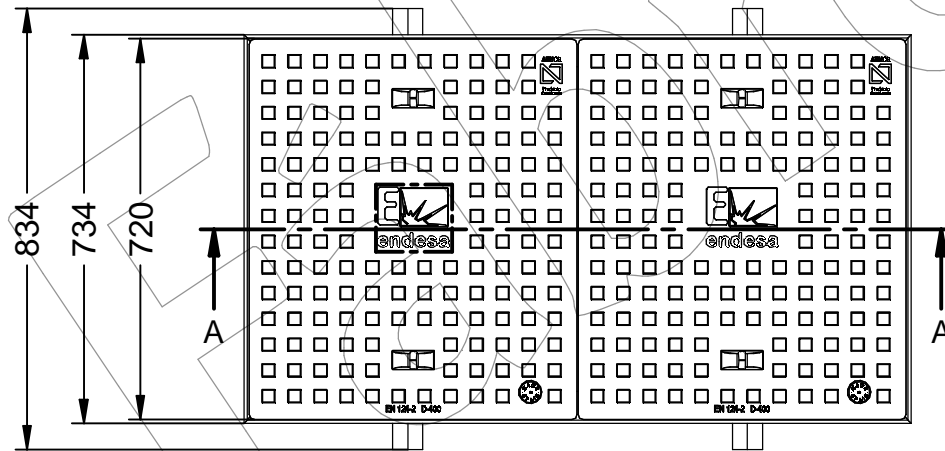
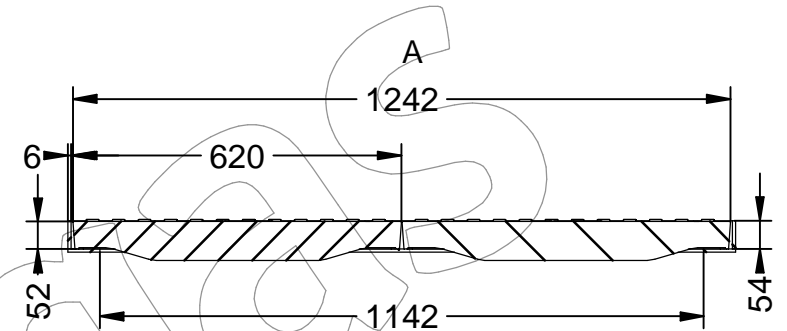
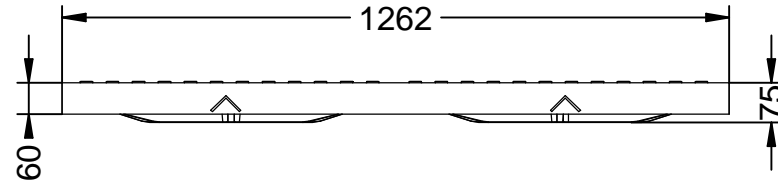
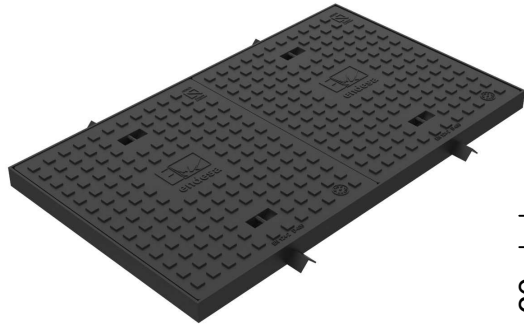

A-2-D-400-CERT-N

Tapa y marco modelo "SEVILLANA", certificada por AENOR de medidas exteriores 1262 x 734 mm y paso libre de 1142 x 614 mm.

Revision: 01 - 13/12/2018

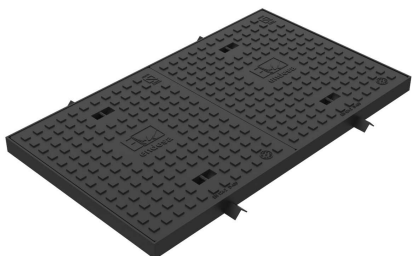

-ES- 

Descripción: Tapa y marco modelo "Sevillana".

Material: Fundición Dúctil EN-GJS-500-7.

Acabado: Pintado negro asfáltico.

Norma: UNE-EN 124.

Clase: D-400.

Embalaje: Paletizado y plastificado.

-EN- 

Description: Top and frame model "Sevillana".

Material: Ductile cast iron EN-GJS-500-7.

Paint finish: Painted black asphalt.

Standard: UNE-EN 124.

Class: D-400.

Packing: Palletized and plasticized.

-PT- 

Descrição: Modelo de topo e armação "Sevillana".

Material: Ferro fundido dúctil EN-GJS-500-7.

Acabamento: Asfalto preto pintado.

Norma: UNE-EN 124.

Classe: D-400

Embalagem: Paletizado e plastificado.

-CA- 

Descripció: Tapa i marc model "Sevillana".

Material: Fosa Dúctil A-GJS-500-7.

Acabat: Pintat negre asfàltic.

Norma: UNE-EN 124.

Classe: D-400.

Embalatge: Paletitzat i plastificat.

-FR- 

Description: Modèle haut et cadre "Sevillana".

Matériau: Fonte ductile EN-GJS-500-7.

Finition: Asphalte noir peint.

Norme: UNE-EN 124.

Classe: D-400.

Emballage: Palettisé et plastifié.